

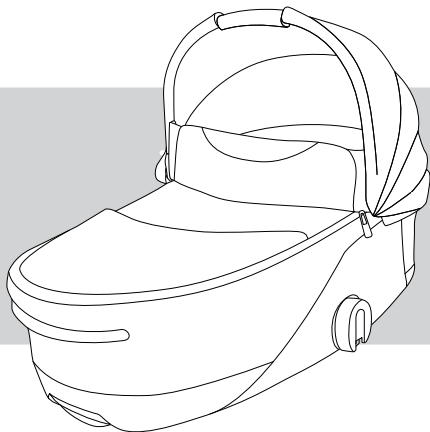

# FOLD

## LUX CARRY COT



Download the  
CYBEX app  
and register your  
product to unlock  
your benefits



**EN** WARNING  
**DE** WARNUNG  
**ES** ADVERTENCIA  
**FR** AVERTISSEMENT  
**PT** AVISOS  
**IT** WARNING  
**NL** WAARSCHUWING  
**PL** OSTRZEŻENIE  
**CS** UPOZORNĚNÍ  
**SK** UPOZORNENIE  
**SL** OPOZORILO  
**HR** UPOZORENJE  
**HU** FIGYELMEZTETÉS  
**SE** VARNING  
**NO** ADVARSEL  
**FI** VAROITUS  
**DA** ADVARSEL  
**ET** HOIATUS  
**LV** BRĪDINĀJUMS  
**LT** PERSPĖJIMAS  
**RU** ВНИМАНИЕ  
**UK** УВАГА  
**TR** UYARI  
**EL** ΠΡΟΕΙΔΟΠΟΙΗΣΗ  
**RO** AVERTISMENTE  
**IS** VIÐVÖRUN  
**MT** TWISSIJA

**HE**  
**AR**  
**FA**  
**YUE** 警告  
**CMN** 警告  
**JA** 警告  
**KO** 경고  
**BG** ПРЕДУПРЕЖДЕНИЕ  
**SR** UPOZORENJE  
**MS** AMARAN  
**HI** चेतावनी  
**TH** คำเตือน  
**SQ** PARALAJMËRIM  
**BS** UPOZORENJE  
**ME** UPOZORENJE  
**MK** ПРЕДУПРЕДУВАЊЕ  
**HY** շօղախոսություն  
**VI** CẢNH BÁO

אזהרה  
تحذير  
اخطار



**EN** Tutorial video  
**DE** Videoanleitung  
**ES** Tutorial en vídeo  
**FR** Vidéo de démonstration  
**PT** Video tutorial  
**IT** Video tutorial  
**NL** Instructievideo  
**PL** Film instruktażowy  
**CS** Výukové video  
**SK** Výukové video  
**SL** Video z navodili  
**HR** Video s uputama  
**HU** Bemutatóvideó  
**SE** Videosjälvstudiekurs  
**NO** Opplæringsvideo  
**FI** Opetusvideo  
**DA** Vejledende video  
**ET** Õppevideo  
**LV** Apmācību video  
**LT** Mokomasis vaizdo įrašas  
**RU** Обучающее видео  
**UK** Навчальне відео  
**TR** Öğretici video  
**EL** Εκπαιδευτικό βίντεο  
**RO** Video tutorial  
**IS** Kennslumyndband  
**MT** Tutorial fuq vidjow

**HE**  
**AR**  
**FA**  
**YUE** 教程視頻  
**CMN** 教程视频  
**JA** チュートリアルビデオ  
**KO** 튜토리얼 동영상  
**BG** Учебно видео  
**SR** Video sa uputstvima  
**MS** Video tutorial  
**HI** ट्यूटोरियल वीडियो  
**TH** วิดีโอแนะนำ  
**SQ** Video udhëzuese  
**BS** Video sa uputstvima  
**ME** Video sa uputstvima  
**MK** Видеоупатство  
**HY** Παιδαγωγικά βίντεο  
**VI** Video hướng dẫn

ורטון הדרכה  
فیدویو تعلیمی  
ویدئوی آموزشی

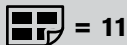

**EN** Maximum weights  
**DE** Maximalgewichte  
**ES** Pesos máximos  
**FR** Poids maximum  
**PT** Pesos máximos  
**IT** Peso massimo  
**NL** Maximumgewicht  
**PL** Dopuszczalna waga  
**CS** Maximální hmotnosti  
**SK** Maximálne hmotnosti  
**SL** Največje teže  
**HR** Maksimalne težine  
**HU** Maximális súlyok  
**SE** Max.vikter  
**NO** Maksimumsvektor  
**FI** Enimmäispainot  
**DA** Maksimumvægt  
**ET** Maksimaalne kaal  
**LV** Maksimālais svars  
**LT** Didžiausi svoriai  
**RU** Максимальная масса  
**UK** Максимальна вага  
**TR** Maksimum ağırlıklar

**EL** Μέγιστο βάρος  
**RO** Greutăți maxime  
**IS** Hámarksþyngd  
**MT** Piżijiet massimi  
**HE** משקלים מרביים  
**AR** الأوزان القصوى  
**FA** حداکثر وزن  
**YUE** 最大重量  
**CMN** 最大重量  
**JA** 最大重量  
**KO** 최대 하중  
**BG** Максимални тегла  
**SR** Maksimalne težine  
**MS** Berat maksimum  
**HI** अधिकतम बजन  
**TH** น้ำหนักสูงสุด  
**SQ** Peshat maksimale  
**BS** Maksimalne težine  
**ME** Maksimalne težine  
**MK** Максимални тежини  
**HY** Առավելագույն քաշեր  
**VI** Các mức cân nặng tối đa

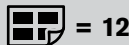

**EN** Product registration  
**DE** Produktregistrierung  
**ES** Registro del producto  
**FR** Enregistrement du produit  
**PT** Registo do produto  
**IT** Registrazione del prodotto  
**NL** Productregistratie  
**PL** Rejestracja produktu  
**CS** Registrace výrobku  
**SK** Registrácia výrobku  
**SL** Registracija izdelka  
**HR** Registracija proizvoda  
**HU** Termékregisztráció  
**SE** Produktregistrering  
**NO** Produktregistrering  
**FI** Tuotteen rekisteröinti  
**DA** Produktregistrering  
**ET** Toote registreerimine  
**LV** Produkta reģistrācija  
**LT** Gaminio registracija  
**RU** Регистрация продукта  
**UK** Реєстрація продукту  
**TR** Ürün kaydı

**EL** Καταχώριση προϊόντος  
**RO** Înregistrarea produsului  
**IS** Skráning tækis  
**MT** Registrazzjoni tal-prodott  
**HE** רישום המוצר  
**AR** تسجيل المنتج  
**FA** ثبت محصول  
**YUE** 產品註冊  
**CMN** 产品注册  
**JA** 製品の登録  
**KO** 제품 등록  
**BG** Регистрация на продукта  
**SR** Registracija proizvoda  
**MS** Pendaftaran produk  
**HI** उत्पाद पंजीकरण  
**TH** การลงทะเบียนผลิตภัณฑ์  
**SQ** Regjistrimi i produktit  
**BS** Registracija proizvoda  
**ME** Registracija proizvoda  
**MK** Регистрација на производ  
**HY** Արարանի գրանցում  
**VI** Đăng ký sản phẩm



= 13

<b>EN</b>	Set up	<b>EL</b>	Στήσιμο
<b>DE</b>	Aufbau	<b>RO</b>	Setare
<b>ES</b>	Instalación	<b>IS</b>	Uppsetning
<b>FR</b>	Montage	<b>MT</b>	Konfigurazzjoni
<b>PT</b>	Preparação	<b>HE</b>	התקנה
<b>IT</b>	Configurazione	<b>AR</b>	تصويب
<b>NL</b>	Opbouw	<b>FA</b>	برپا کردن
<b>PL</b>	Montaż	<b>YUE</b>	設置
<b>CS</b>	Nastavení	<b>CMN</b>	设置
<b>SK</b>	Nastavenie	<b>JA</b>	セットアップ
<b>SL</b>	Nastavitev	<b>KO</b>	설정
<b>HR</b>	Postavljanje	<b>BG</b>	Настройка
<b>HU</b>	Felszerelés	<b>SR</b>	Postavljanje
<b>SE</b>	Inställning	<b>MS</b>	Persediaan
<b>NO</b>	Oppsett	<b>HI</b>	सेट अप
<b>FI</b>	Asennus	<b>TH</b>	การติดตั้ง
<b>DA</b>	Opsætning	<b>SQ</b>	Konfigurimi
<b>ET</b>	Seadistamine	<b>BS</b>	Postavljanje
<b>LV</b>	Uzstādīšana	<b>ME</b>	Postavljanje
<b>LT</b>	Nuostatos	<b>MK</b>	Поставување
<b>RU</b>	Установка	<b>HY</b>	Շարժափորով
<b>UK</b>	Встановлення	<b>VI</b>	Cài đặt
<b>TR</b>	Kurulum		



= 16

<b>EN</b>	Usage on the stroller frame	<b>EL</b>	Χρήση στο πλαίσιο του καροτσιού
<b>DE</b>	Verwendung auf dem Kinderwagengestell	<b>RO</b>	Utilizare pe cadrul căruciorului
<b>ES</b>	Uso en el bastidor del cochecito	<b>IS</b>	Notkun á ramma vagnsins
<b>FR</b>	Utilisation sur le cadre du landau	<b>MT</b>	Użu fuq il-qafas tal-pramm
<b>PT</b>	Utilização na estrutura do carrinho	<b>HE</b>	שימוש במסגרת העגלה
<b>IT</b>	Uso del telaio del passeggino	<b>AR</b>	الاستخدام على إطار عربة الأطفال
<b>NL</b>	Gebruik op het frame van de wandelwagen	<b>FA</b>	استفاده بر روی شاسی کالسکه
<b>PL</b>	Stosowanie na ramie wózka	<b>YUE</b>	在嬰兒車車架上使用
<b>CS</b>	Použití na rámu kočárku	<b>CMN</b>	在嬰兒車車架上使用
<b>SK</b>	Použitie na ráme kočíka	<b>JA</b>	ベビーカーフレームの使用
<b>SL</b>	Uporaba na okvirju vozička	<b>KO</b>	유모차 프레임 사용
<b>HR</b>	Upotreba na okviru kolica	<b>BG</b>	Употреба върху рамката на детската количка
<b>HU</b>	A babakocsi keretén való használat	<b>SR</b>	Upotreba na okviru kolica
<b>SE</b>	Användning på sittvagnsramen	<b>MS</b>	Penggunaan pada rangka kerusi tolak
<b>NO</b>	Bruk på barnevognrammen	<b>HI</b>	स्ट्रोलर फ्रेम पर उपयोग
<b>FI</b>	Käyttö rattaiden rungolla	<b>TH</b>	การใช้งานบนเฟรมรถเข็นเด็ก

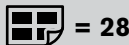

= 28

<b>DA</b>	Anvendelse på klapvognsstellet	<b>SQ</b>	Përdorimi në skeletin e karrocës	<b>EN</b>	Sun canopy	<b>EL</b>	Κουκούλα για τον ήλιο
<b>ET</b>	Kasutamine jalutuskäru raamil	<b>BS</b>	Upotreba na okviru kolica	<b>DE</b>	Sonnenerdeck	<b>RO</b>	Copertină
<b>LV</b>	Izmantošana uz bērnu ratiņu rāmja	<b>ME</b>	Upotreba na okviru kolica	<b>ES</b>	Capota para el sol	<b>IS</b>	Sólargjald
<b>LT</b>	Vežimėlio rėmo naudojimas	<b>MK</b>	Користење на рамката на количка	<b>FR</b>	Pare-soleil	<b>MT</b>	Kopertura mix-xemx
<b>RU</b>	Использование на раме детской коляски	<b>HY</b>	Մանկասայլակի կմախքի գործածությունը	<b>PT</b>	Capota solar	<b>HE</b>	שמש תפוח
<b>UK</b>	Використання рами візка	<b>VI</b>	Sử dụng trên khung xe đẩy	<b>IT</b>	Parasole	<b>AR</b>	مظلة الشمس
<b>TR</b>	Çocuk arabası kasasında kullanim			<b>NL</b>	Zonnekap	<b>FA</b>	سایبان
				<b>PL</b>	Oslona przeciwsłoneczna	<b>YUE</b>	遮陽蓬
				<b>CS</b>	Stříška proti slunci	<b>CMN</b>	遮阳蓬
				<b>SK</b>	Strieška proti slnku	<b>JA</b>	日よけ力/バー
				<b>SL</b>	Senčnik za zaščito pred soncem	<b>KO</b>	선 캐노피
				<b>HR</b>	Tenda za sunce	<b>BG</b>	Тента
				<b>HU</b>	Kupola	<b>SR</b>	Tenda za sunce
				<b>SE</b>	Solsufflett	<b>MS</b>	Kanopi matahari
				<b>NO</b>	Solskjerm	<b>HI</b>	धूप छतरी
				<b>FI</b>	Aurinkokatos	<b>TH</b>	หลังคาบังแดด
				<b>DA</b>	Solkaleche	<b>SQ</b>	Strea për diellin
				<b>ET</b>	Päikesevari	<b>BS</b>	Tenda za sunce
				<b>LV</b>	Saules aizsegs	<b>ME</b>	Tenda za sunce
				<b>LT</b>	Stogelis nuo saulės	<b>MK</b>	Стреа за сонце
				<b>RU</b>	Солнцезащитный козырек	<b>HY</b>	Արևապաշտպան ծածկ
				<b>UK</b>	Тент від сонця	<b>VI</b>	Mái che nắng
				<b>TR</b>	Güneş başlığı		

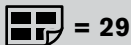

<b>EN</b>	Panorama view window	<b>EL</b>	Πανοραμικό παράθυρο	<b>RU</b>	Панорамное смотровое окошко
<b>DE</b>	Panorama-Fenster	<b>RO</b>	Fereastra cu vedere panoramică	<b>UK</b>	Панорамне віконце
<b>ES</b>	Ventana de visibilidad panorámica	<b>IS</b>	Viðmynd	<b>TR</b>	Panorama penceresi
<b>FR</b>	Fenêtre panoramique	<b>MT</b>	Tieqa biex tara l-veduta	<b>HY</b>	Պանորամային պատուհան
<b>PT</b>	Janela panorâmica	<b>HE</b>	חלון פנורמי	<b>VI</b>	Cửa sổ nhìn toàn cảnh
<b>IT</b>	Finestrino per vista panoramica	<b>AR</b>	نافذة بانورامية		
<b>NL</b>	Panoramavenster	<b>FA</b>	پنجره با نمای پانوراما		
<b>PL</b>	Okienko z panoramicznym widokiem	<b>YUE</b>	全景窗口		
<b>CS</b>	Panoramatické okno	<b>CMN</b>	全景窗口		
<b>SK</b>	Panoramatické okno	<b>JA</b>	パノラマビューウィンドウ		
<b>SL</b>	Okno s panoramskim pogledom	<b>KO</b>	파노라마 뷰 윈도우		
<b>HR</b>	Panoramski prozorčić	<b>BG</b>	Прозорец за панорамна гледна		
<b>HU</b>	Panoramikus kitekintő ablak	<b>SR</b>	Panorama prozorčić		
<b>SE</b>	Panoramafönster	<b>MS</b>	Tetingkap pandangan panorama		
<b>NO</b>	Panoramavindu	<b>HI</b>	पैनोरमा व्यू विंडो		
<b>FI</b>	Panoraamaikkuna	<b>TH</b>	หน้าต่างมุมมองพาโนรามา		
<b>DA</b>	Panoramavindue	<b>SQ</b>	Dritarja e shikimit panoramik		
<b>ET</b>	Panoraamvaatega aken	<b>BS</b>	Panorama prozorčić		
<b>LV</b>	Panorāmas skata logs	<b>ME</b>	Panorama prozorčić		
<b>LT</b>	Panoraminis langelis	<b>MK</b>	Панорамски прозорец		



= 30

**EN** Folding  
**DE** Faltung  
**ES** Plegado  
**FR** Pliant  
**PT** Fecho  
**IT** Ripiegamento  
**NL** Vouwen  
**PL** Składanie  
**CS** Skládání  
**SK** Zloženie  
**SL** Zlaganje  
**HR** Preklapanje  
**HU** Összecsukás  
**SE** Ihopfällning  
**NO** Sammenlegging  
**FI** Kokoon taittaminen  
**DA** Sammenklapning  
**ET** Kokkuvoltimine  
**LV** Salocīšana  
**LT** Lankstymas  
**RU** Складывание  
**UK** Складання  
**TR** Katlama

**EL** Αναδίπλωση  
**RO** Pliere  
**IS** Brjótta saman  
**MT** Tiwi  
**HE** קיפול  
**AR** قابلية للطي  
**FA** تا کردن  
**YUE** 折疊  
**CMN** 折叠  
**JA** 折りたたみ  
**KO** 접기  
**BG** Сгъване  
**SR** Preklapanje  
**MS** Lipat  
**HI** फोल्डिंग  
**TH** การพับ  
**SQ** Palosja  
**BS** Preklapanje  
**ME** Preklapanje  
**MK** Склопување  
**HY** Ծախելը  
**VI** Gập lại



= 31

**EN** Rain cover  
**DE** Regenverdeck  
**ES** Funda para la lluvia  
**FR** Housse de pluie  
**PT** Capa de chuva  
**IT** Parapioggia  
**NL** Regenhoes  
**PL** Osłona od deszczu  
**CS** Pláštěnka  
**SK** Kryt proti dažďu  
**SL** Dežna prevleka  
**HR** Pokrivač za kišu  
**HU** Esővédő  
**SE** Regnskydd  
**NO** Kalesje  
**FI** Sadesuoja  
**DA** Regnslag  
**ET** Vihmakate  
**LV** Pretlietus pārvalks  
**LT** Uždangalas nuo lietaus  
**RU** Дождевик  
**UK** Дошовник  
**TR** Yağmurluk

**EL** Καλύπτρα βροχής  
**RO** Prelată de ploaie  
**IS** Regn yfirbreiðsla  
**MT** Għata mix-xita  
**HE** כיסוי גשם  
**AR** غطاء المطر  
**FA** روکش باران  
**YUE** 防雨罩  
**CMN** 防雨罩  
**JA** 雨よけ  
**KO** 레인커버  
**BG** Дъждобран  
**SR** Pokrivač za kišu  
**MS** Pelindung hujan  
**HI** रेत कवर  
**TH** ฝ้ายคลุมกันฝน  
**SQ** Mbulesë për shiun  
**BS** Pokrivač za kišu  
**ME** Pokrivač za kišu  
**MK** Прекривка за дожд  
**HY** Անձրևապաշտպան  
**VI** Tấm che mưa

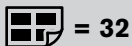

<b>EN</b>	Removing the fabric	<b>EL</b>	Αφαίρεση του υφάσματος
<b>DE</b>	Entfernen des Bezuges	<b>RO</b>	Îndepărtarea țesăturii
<b>ES</b>	Quitar la tela	<b>IS</b>	Fjarlægja efni
<b>FR</b>	Retrait du tissu	<b>MT</b>	Tneħhija tad-drapp
<b>PT</b>	Remover o tecido	<b>HE</b>	הסרת הבד
<b>IT</b>	Rimozione del tessuto	<b>AR</b>	فك القماش
<b>NL</b>	De stof verwijderen	<b>FA</b>	برداشتن پارچه
<b>PL</b>	Zdejmowanie pokrycia	<b>YUE</b>	拆除罩布
<b>CS</b>	Odstranění látky	<b>CMN</b>	拆除罩布
<b>SK</b>	Odstránenie látky	<b>JA</b>	カバーの取り外し
<b>SL</b>	Odstranjevanje blaga	<b>KO</b>	페브릭 제거
<b>HR</b>	Uklanjanje tkanine	<b>BG</b>	Демонтиране на плата
<b>HU</b>	Huzat eltávolítása	<b>SR</b>	Uklanjanje tkanine
<b>SE</b>	Ta bort tyget	<b>MS</b>	Menanggalkan fabrik
<b>NO</b>	Fjerne stoffet	<b>HI</b>	कपड़ा हटाना
<b>FI</b>	Kankaan poisto	<b>TH</b>	การถอดผ้า
<b>DA</b>	Fjernelse af stoffet	<b>SQ</b>	Heqja e copës
<b>ET</b>	Kanga eemaldamine	<b>BS</b>	Uklanjanje tkanine
<b>LV</b>	Pārklājuma atvienošana	<b>ME</b>	Uklanjanje tkanine
<b>LT</b>	Audinio nuėmimas	<b>MK</b>	Отстранување на навлаката
<b>RU</b>	Снятие ткани	<b>HY</b>	Գործվածքը հանելը
<b>UK</b>	Зняття матерії	<b>VI</b>	Tháo phần vải bọc
<b>TR</b>	Kılıfı çıkarma		

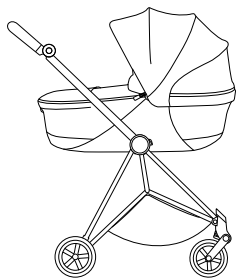

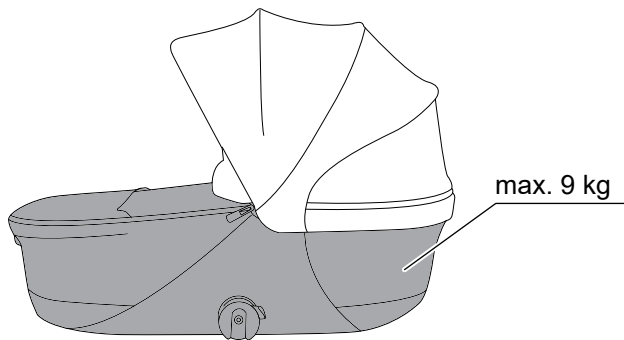

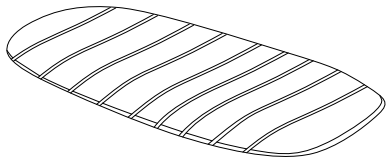
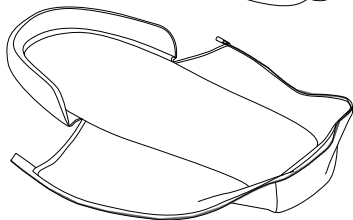
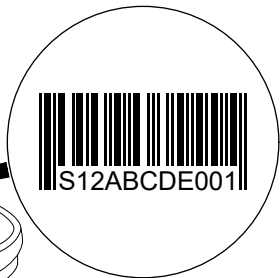
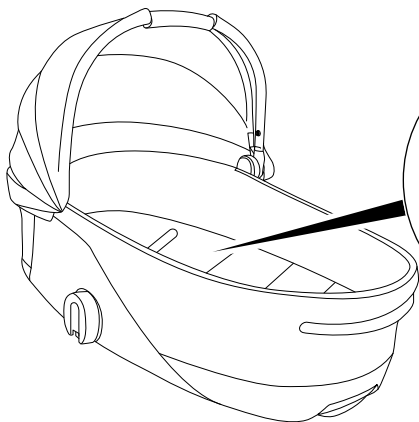

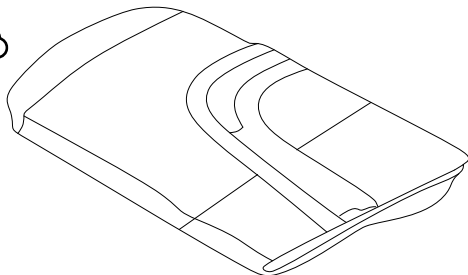
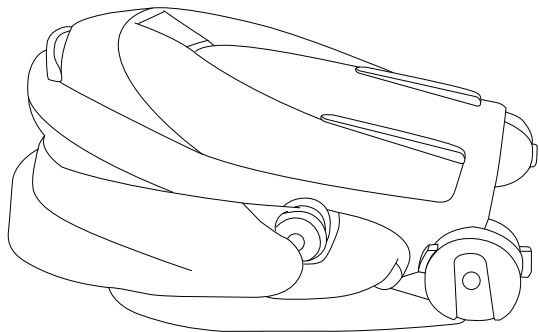

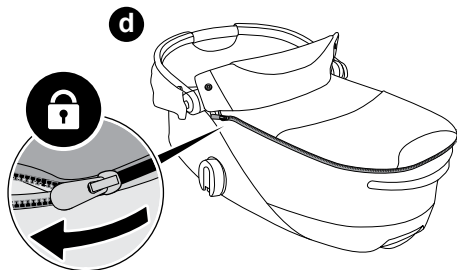
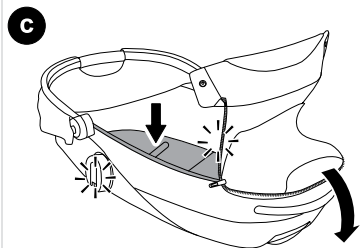
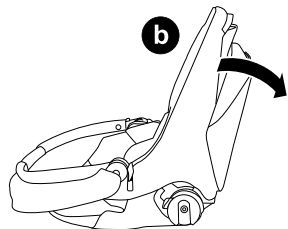
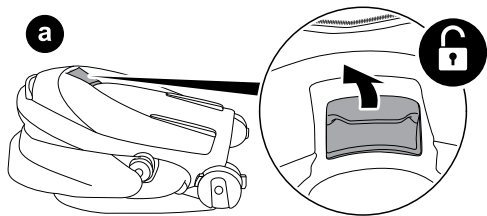

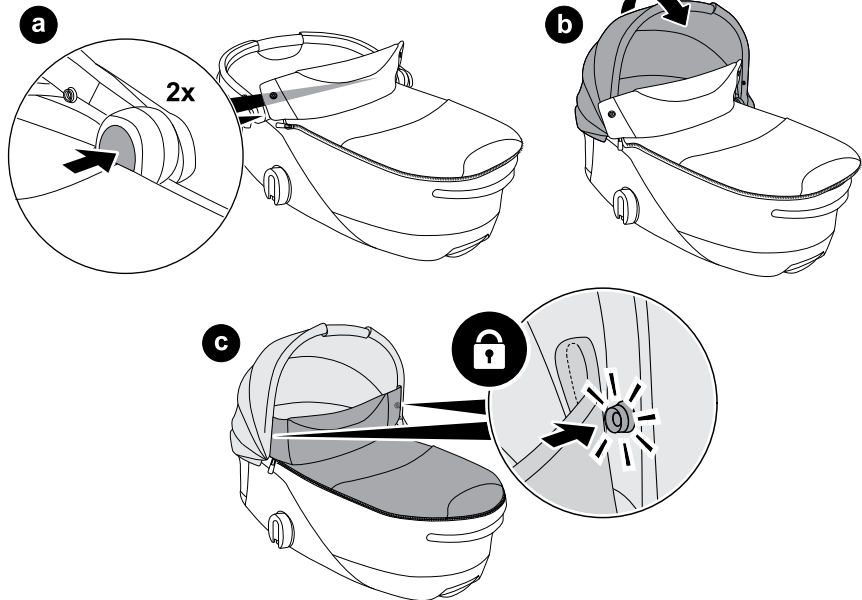



## PRIAM

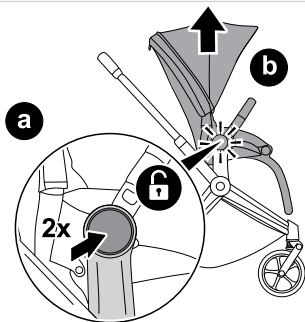

1

## MIOS

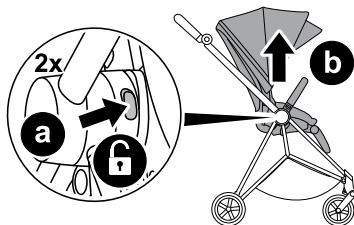

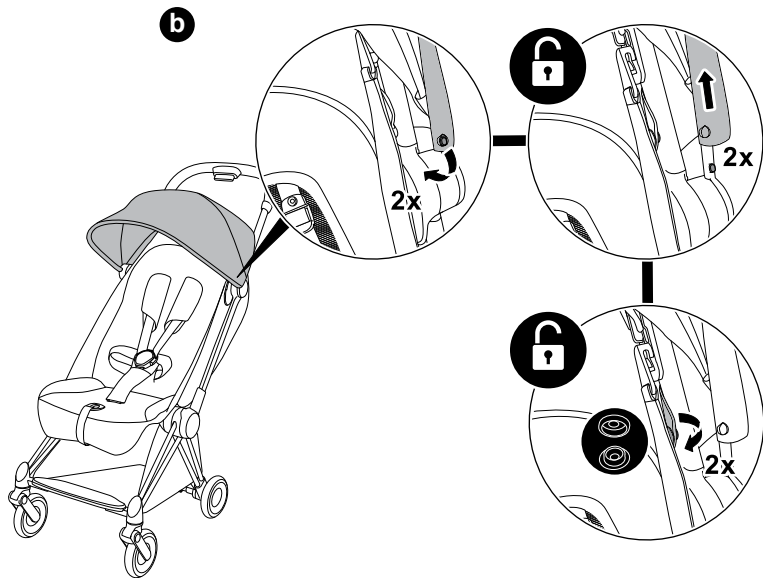



COYA

**C**

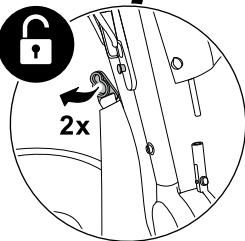
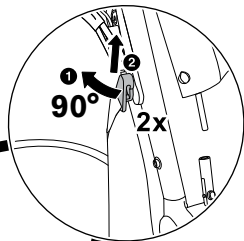
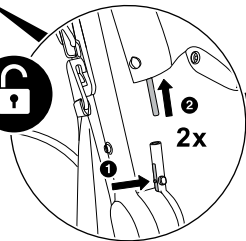

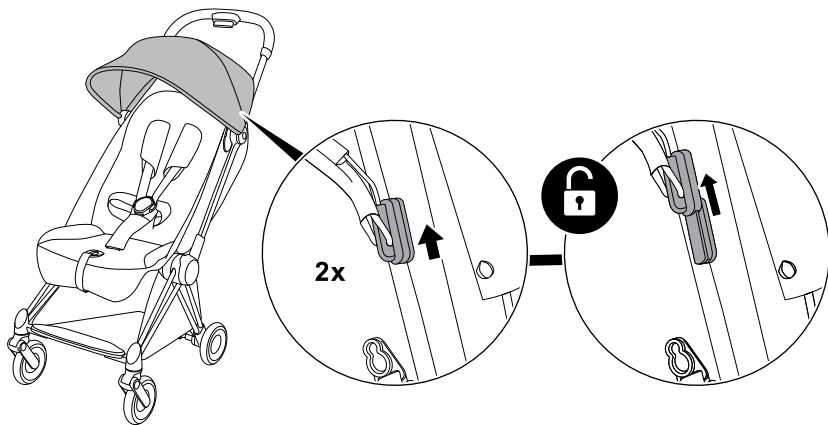
**d**



COYA

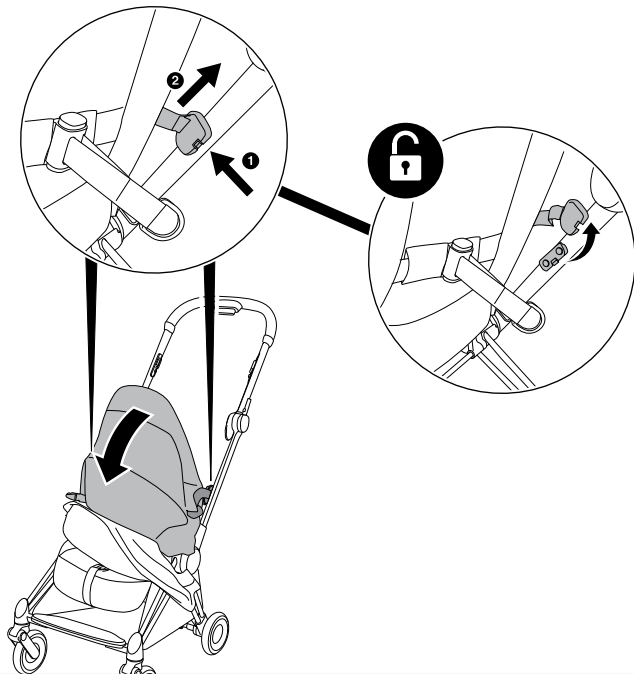

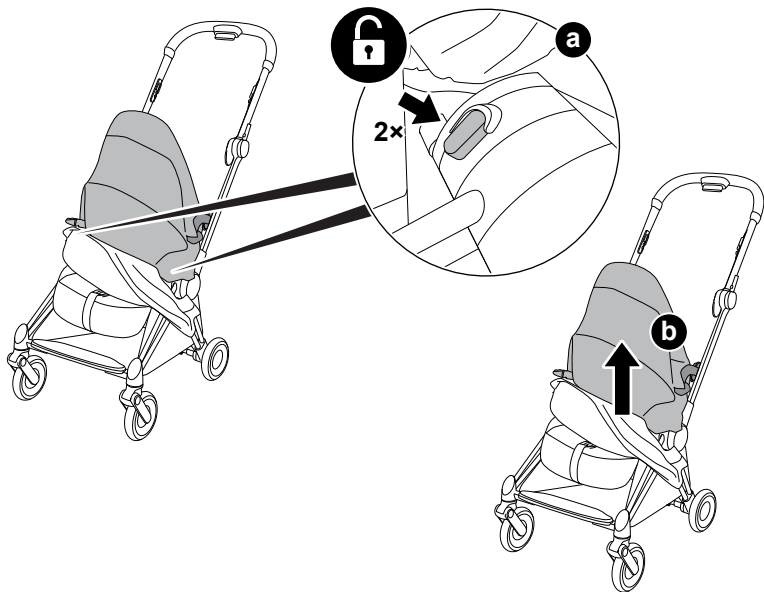



PRIAM

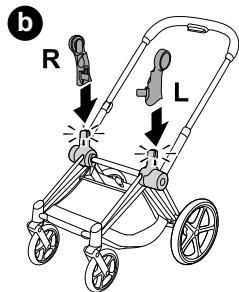
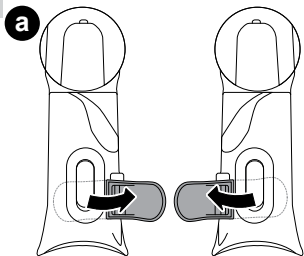

2

PRIAM

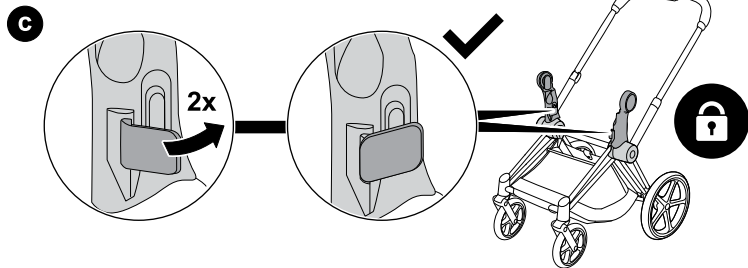

22

3

COYA

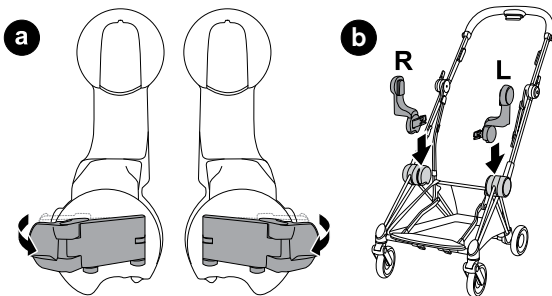

6



COYA

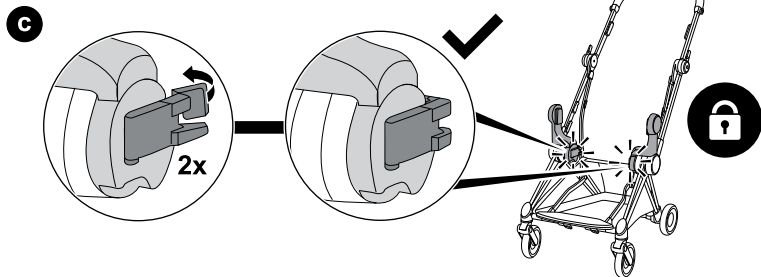

7

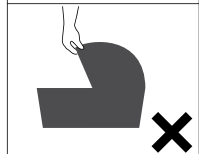
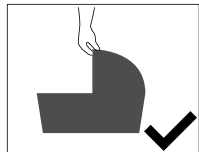
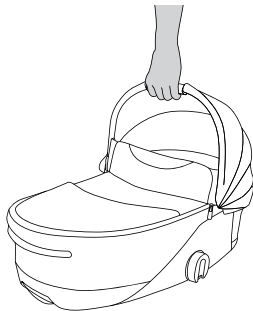
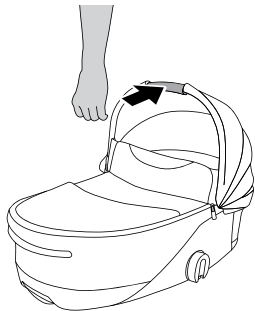

PRIAM

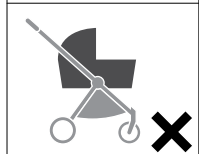
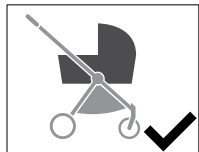
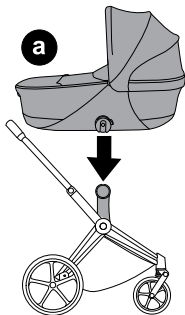

# PRIAM

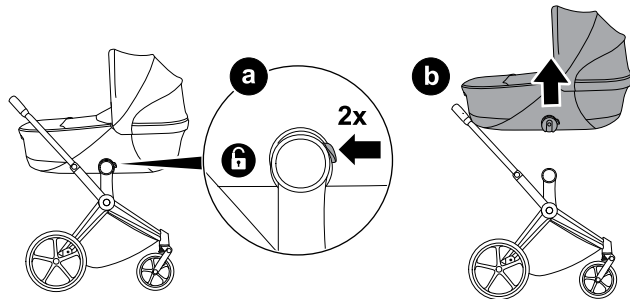

5



# MIOS

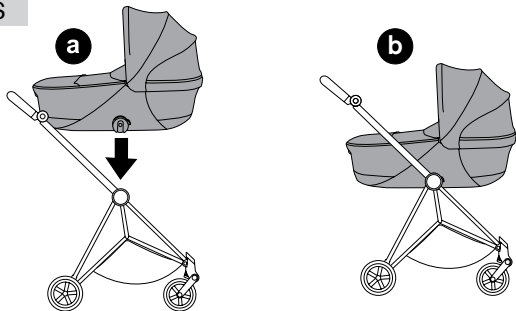

2

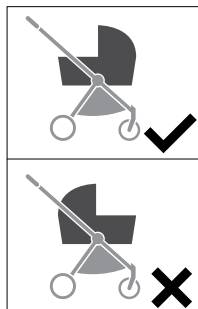



MIOS

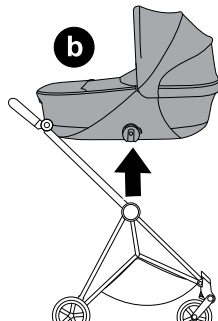
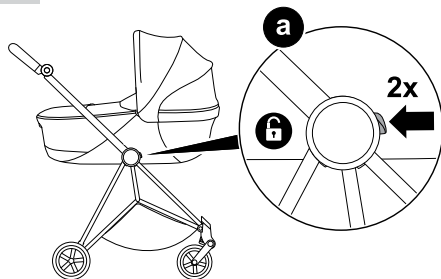

3

COYA

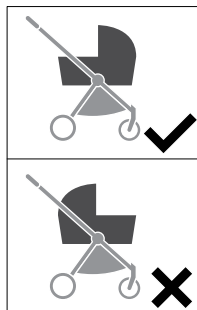
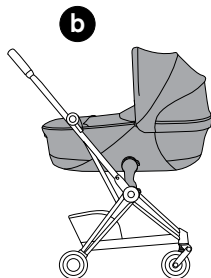
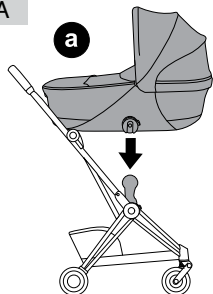

26

8

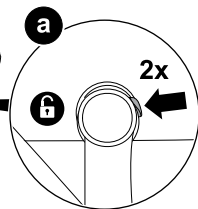
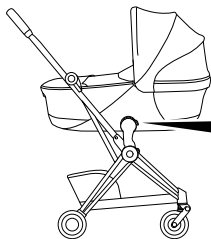

**b**

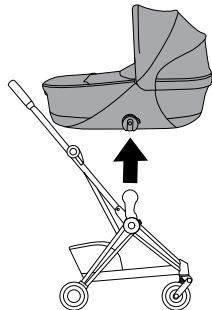

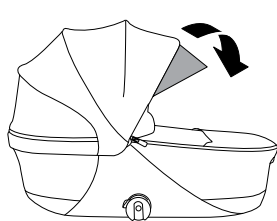
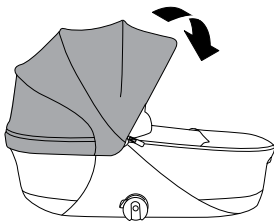
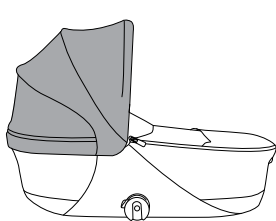
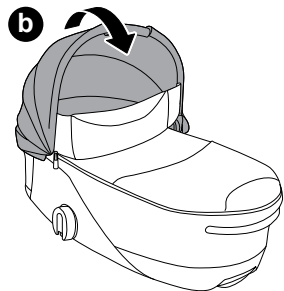
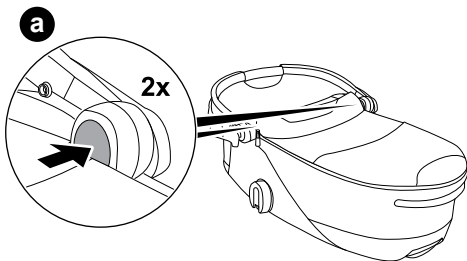

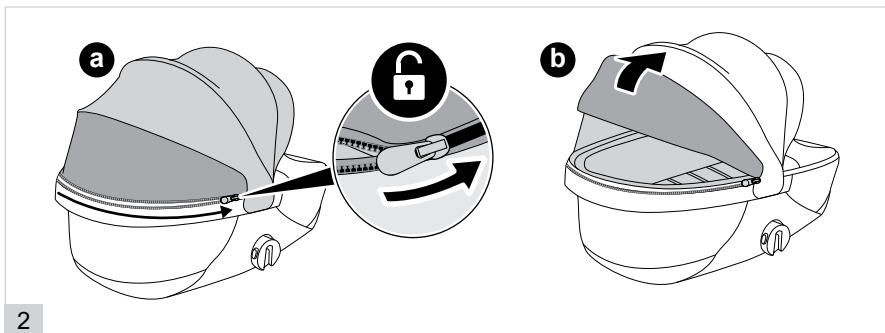
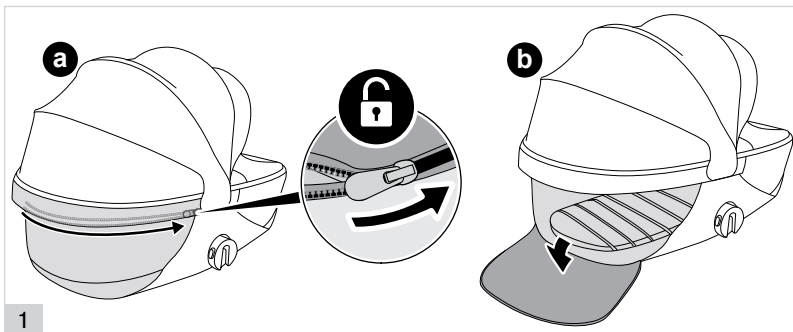

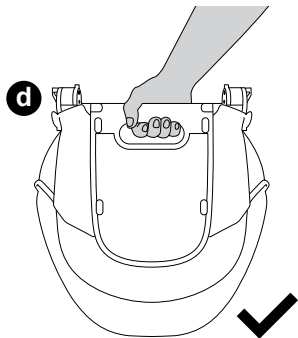
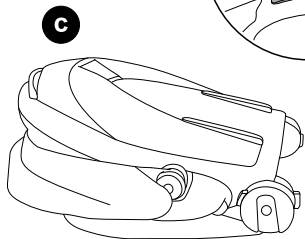
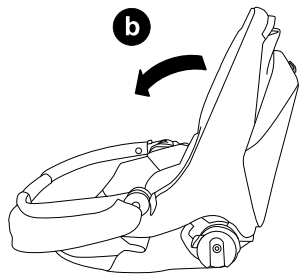
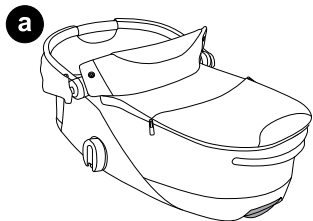

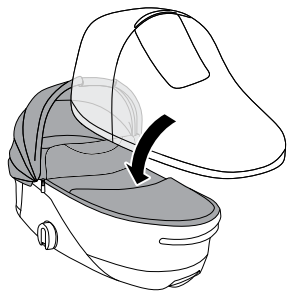

1

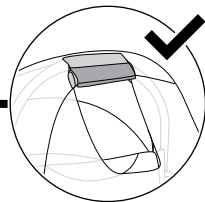
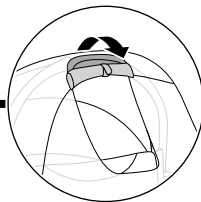
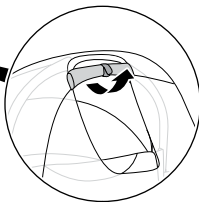
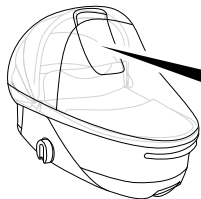

2

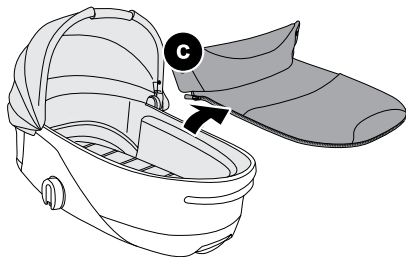
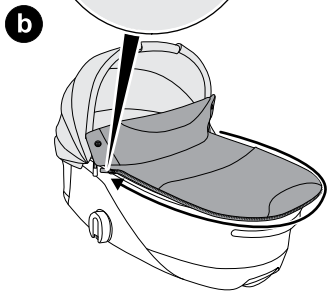
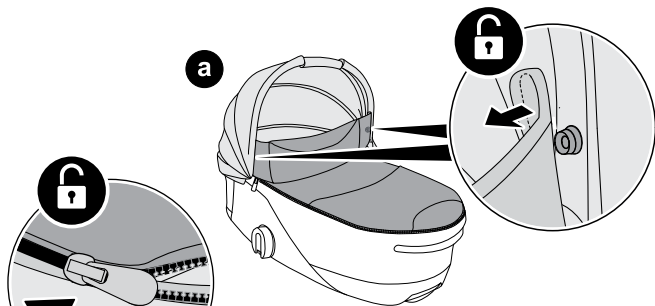

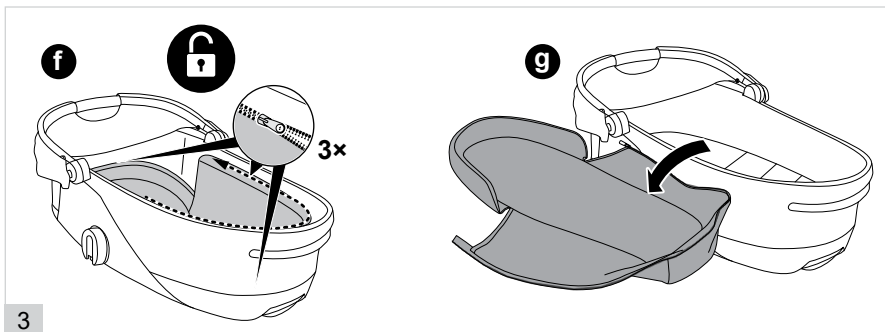
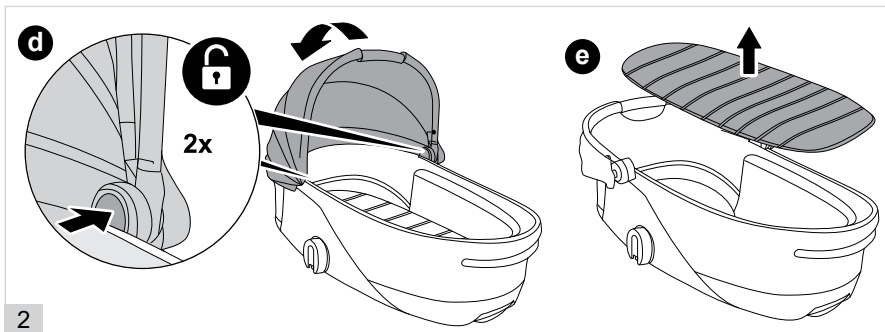

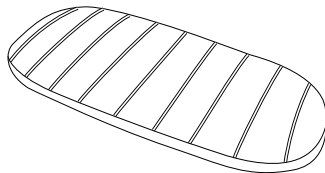
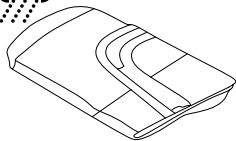
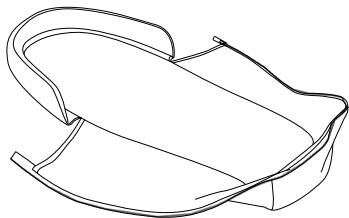
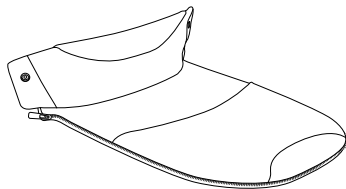
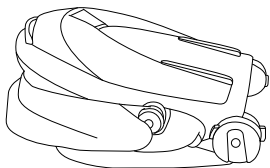





CYBEX GmbH

Riedingerstr. 18 | 95448 Bayreuth | Germany  
+49 (0) 921-78 511-0 | [info@cybex-online.com](mailto:info@cybex-online.com)

[www.cybex-online.com](http://www.cybex-online.com)

 **cybex**  
PLATINUM